

# CRANE GIRDER SURGE CONNECTORS

Crane girders need to be firmly fixed to the columns on which they sit. They also need to transfer horizontal forces from the cranes into the building. With small buildings and modest forces, the girders can carry the forces through the fixing at the girder bottom flange. In steel works, aluminium plants and other heavy facilities, there are often problems in carrying these forces. Typically, the crane girder sits on one column and the building roof is carried on another column. The top of the girder is

connected to the building roof column. This connection is designed to carry the majority of the horizontal force from the crane, perpendicular to the girder axis. Traditionally this detail was normally some form of diaphragm plate or plate with slotted holes. Experience shows that these details are not able to carry the forces reliably and they do not work for the life of the plant. This is because they need to be able to accommodate significant movements due to crane girder deflections and movements. These are due to crane girder bending and differential vertical deflection of the two columns. However, they also need to be strong enough to take the significant forces.

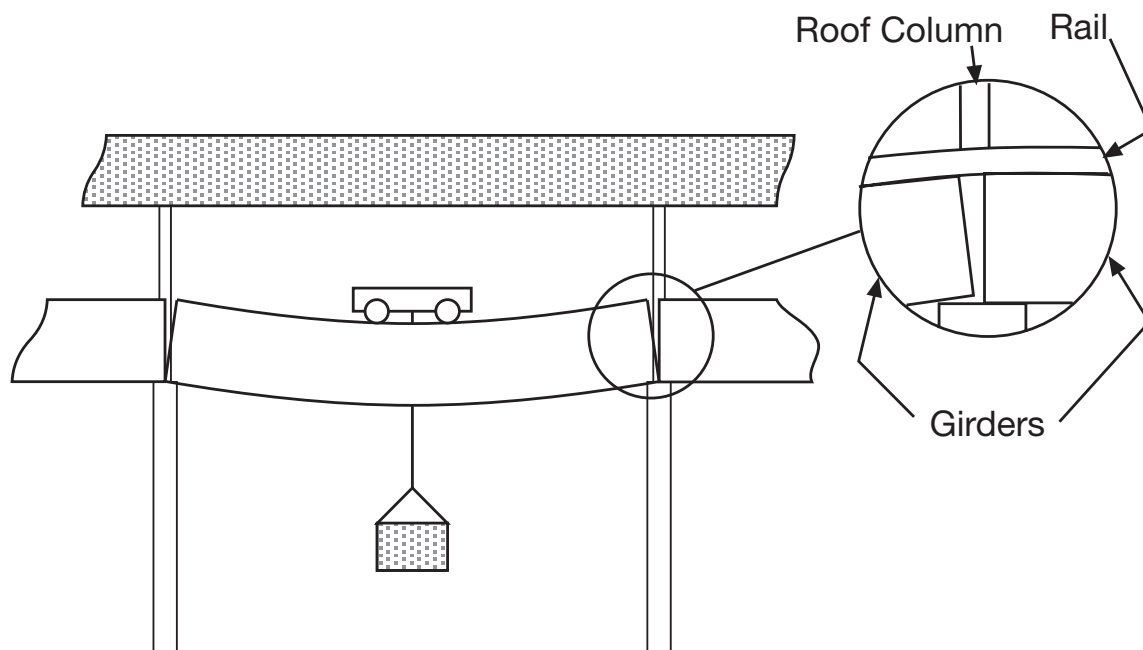

Gantrail crane girder surge connectors eliminate the difficulties in transferring these horizontal forces and deflections from the crane girders into the building. The heart of the Gantrail product is a mechanical link. This has a ball and socket joint at each end. These can take significantly more movement than the traditional structural connections.

The structural engineer needs to consider the full design of this detail in the knowledge of the loading and use anticipated. It is possible to

design with the full force that will occur at a pair of columns being carried on either one connector or two. This is dependent on the method of carrying load from one girder to another. Gantrail can supply 'tongue and groove' devices for carrying the load from one girder to the adjacent. The following tables give allowable loads as calculated on the basis of British Standard BS 449. This standard is similar in content to the codes for design used in many countries.

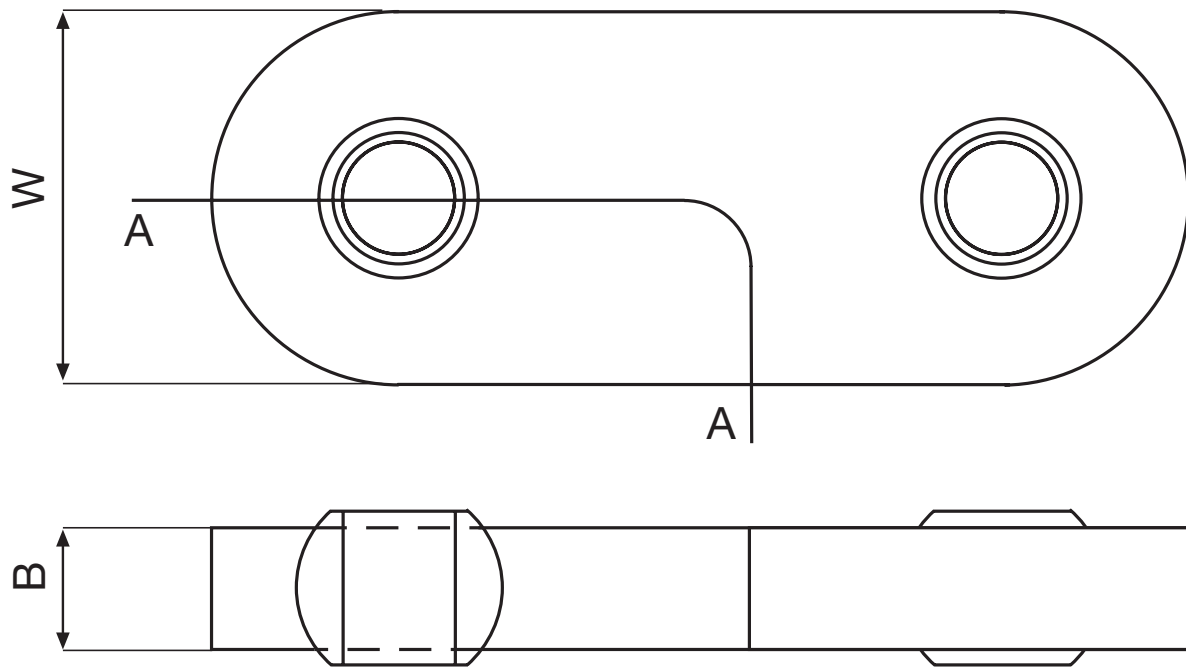

Section A-A

**TABLE 1**

Using BS 3692 ISO 8.8 Grade Precision High Tensile Bolts Design to BS 449. Bolts in close tolerance holes. Hole diameter to be bolt diameter + 0.15mm - 0mm. Top and bottom plates to be clamped together and drilled. Threads to be outside shearing plane. Plates should have a tensile strength of 430N/mm<sup>2</sup>

NOTE Loads are quoted in kN. To convert to tonnes force divide by 9.81. Plate thickness quoted is the minimum for strength of the plate and the bolt. Long links may be subject to buckling. This should form part of the design check.

In practice Gantrail usually suggest that the only 50% of the actual allowable design figures

BOLT DIAMETER PLATE	THICKNESS (B) (MM)	PLATE WIDTH (W) (MM)	ALLOWABLE DESIGN FORCE (kN)
12	12	46	26
16	15	61	47
20	20	77	74
24	20	94	106
30	25	117	165
36	30	141	238
39	30	156	280
42	35	164	324
45	35	178	372
52	40	205	497
56	45	218	576

be used, thus allowing a considerable safety factor.

## TABLE 2

Using BS 4604 High Strength Friction Grip Bolts

*Part 1: General Grade. Hole diameter bolts 16mm - 24mm diameter. Bolt diameter + 2mm. Bolts 30mm and above bolt diameter + 3mm. Bolts to be tightened to minimum shank tension defined in BS 4604. Plates Grade 43 should have a tensile strength of 430N/mm<sup>2</sup>.*

Mating contact surfaces of plates in HSFG connections to be blast cleaned and unpainted or aluminium metal sprayed.

## DESIGN RESPONSIBILITY

This technical guidance note has been prepared on the basis of many years experience at Gantry Railing Limited. However, crane girders and surge connectors are significant structural items in many designs and installations, and it is not possible for Gantry to fully appreciate all the local circumstances. Thus the ultimate responsibility for the design and installation must normally rest with the competent local engineer.

BOLT DIAMETER	MIN. PLATE THICKNESS (MM)	MIN END DISTANCE (MM)	ALLOWABLE DESIGN FORCE (kN)
16	10	30	59.2
20	10	40	92.6
24	12	50	133.1
30	15	60	183.9
36	20	75	268.7