

RAIL ANCHOR POINTS and expansion joints

INTRODUCTION

Short lengths of rail may move along the track. Long lengths of rail should not move when correctly fastened. It may sometimes be desirable to fix the rail for some operational or design reason and to install expansion joints. This note sets out guidance on the use of rail anchors points in designing an installation.

DISCUSSION

Gantrail clips apply a force to the rail through the rubber block (the nose). The magnitude of this force on initial installation is estimated to range between 0.4 kN and 3.5 kN. The actual figure depends on the length and depth of nose and its amount of compression.

The forces that tend to result in rails creeping along the track include crane acceleration or braking and thermal expansion. For the rail to

slip during crane acceleration or braking, the coefficient of friction between the crane wheels and rail must be higher than that between the rail and its support. In practice they are likely to be much the same and any small differences should be catered for by the anchoring effect of the clips. Thermal expansion does not tend to cause major rail movement. This is because the structure expands with the rail and the crane tends to anchor the rail, particularly when parked.

Consider an example: 30 metres of rail fixed with pairs of clips at 600mm centres; the rail will be fixed with 100 clips. The rail anchoring force due to the clips is a minimum of 40 kilo Newtons or 4 tonnes force. There are unlikely to be any significant forces on the rail to cause it to move significantly along the track.

DESIGN OF RAIL ANCHORS

It is possible to encounter circumstances where the rails will move and in such cases a rail anchor may be used. The preferred detail is constructed as shown in figure 1. Plates are welded to the top surface of the bottom flange of the rail. These overhang the side of the rail

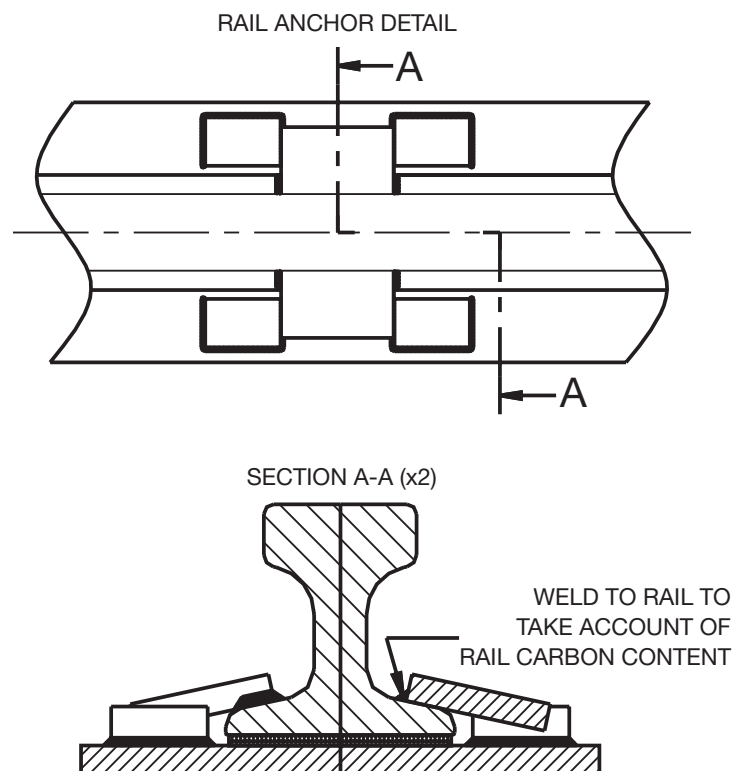

FIG 1

by 100 to 150mm. Blocks are then welded to the rail support surface to prevent the rail from moving longitudinally. These blocks are positioned away from the edge of the rail so that sideways adjustment of the rail is still possible. The welds to the rail require low hydrogen (or austenitic) electrodes and an appropriate degree of preheat. This will depend on the carbon content or carbon equivalent of the rail steel. It should be possible to weld an anchor point without damaging pad beneath the rail. The rail temperature should be kept below 150° C at all times.

An alternative to a central fixed point is to use blocks at the end of the rail. These are normally welded to the rail support, some 50 to 100mm from the end of the rail. This is normally a better solution to ensuring rails do not move than the use of a fixed point.

STRUCTURAL DESIGN CONSIDERATIONS

The way that the forces from the rail are transferred into the structure may have an influence on the design of the structure. When necessary the structural designer or

maintenance engineer's advice should be obtained before the rail installation is made or changed.

DESIGN OF RAIL EXPANSION JOINTS

Rail expansion joints do not always work effectively and are better avoided. If they are essential some of the design features that may be used are shown in the sketch below. Note that the rail web is reinforced, (before it is machined) to maintain its crush resistance strength. The head of the rail may be hardened at the joint with hard facing weld material. Gantrail can advise on details.

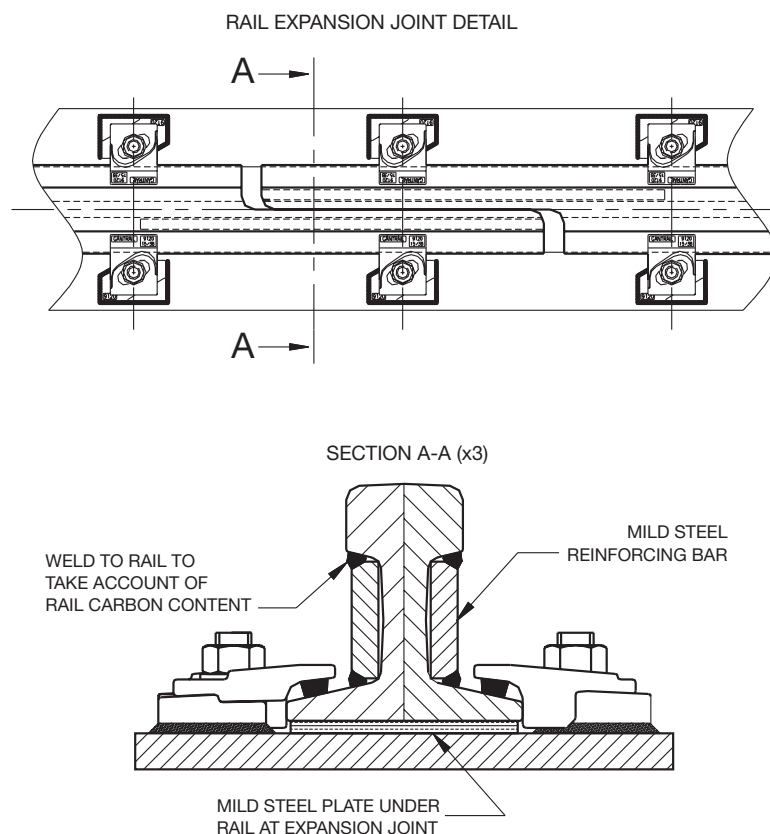

FIG 2