

THIRD ANGLE PROJECTION

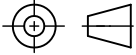

FOR GUIDANCE ONLY
THIS INFORMATION HAS BEEN
PROVIDED IN GOOD FAITH BUT
SPECIFICATIONS DO CHANGE

Edition A

Date 17/06/14

Scale 1:1 @ A4

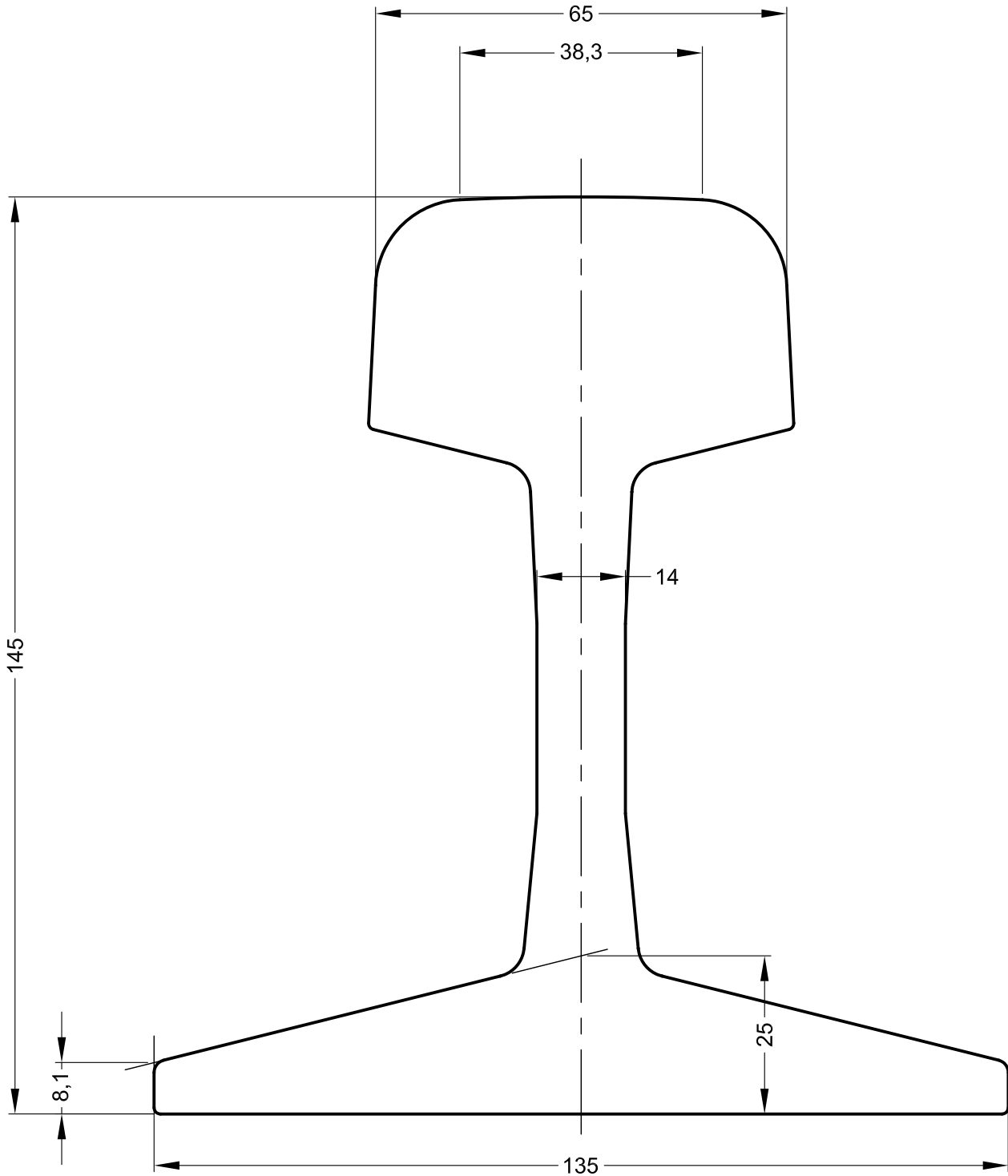

NOTE: THE PROPERTIES SPECIFIED BELOW HAVE BEEN CALCULATED USING AUTOCAD SOFTWARE AND ARE ACCURATE AT THE TIME OF THIS DRAWING ISSUE. THESE FIGURES MAY DIFFER SLIGHTLY FROM THOSE PUBLISHED IN THE STANDARD FOR THE RAIL.

GANTRAIL[®]

Rail Mounting Systems

THE TECHNICAL DATA CONTAINED IN THIS DRAWING IS THE PROPERTY OF GANTRY RAILING LIMITED AND IS SUBJECT TO COPYRIGHT ©

Gantry Railing Limited

SUDMEADOW ROAD, HEMPSTED
GLOUCESTER GL2 5HG, ENGLAND
Tel: (01452)300688 Fax (01452)300198
International Dialling # 44.1452
<http://www.gantrail.com>
E-Mail: info@gantrail.com

Rail Designation	46 UNI [46 E4]
Rail Origin	INTERNATIONAL
Standard	BS EN13674-1
Area of section	5989 mm ²
Calculated Mass	47.02 kg/m
Neutral Axis to base	68.8 mm
Moment of Inertia	I _{xx} 1689 cm ⁴ I _{yy} 338.4 cm ⁴