

THIRD ANGLE PROJECTION

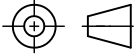

FOR GUIDANCE ONLY  
THIS INFORMATION HAS BEEN  
PROVIDED IN GOOD FAITH BUT  
SPECIFICATIONS DO CHANGE

Edition B

Date 06/07/10

Scale 1:1 @ A4

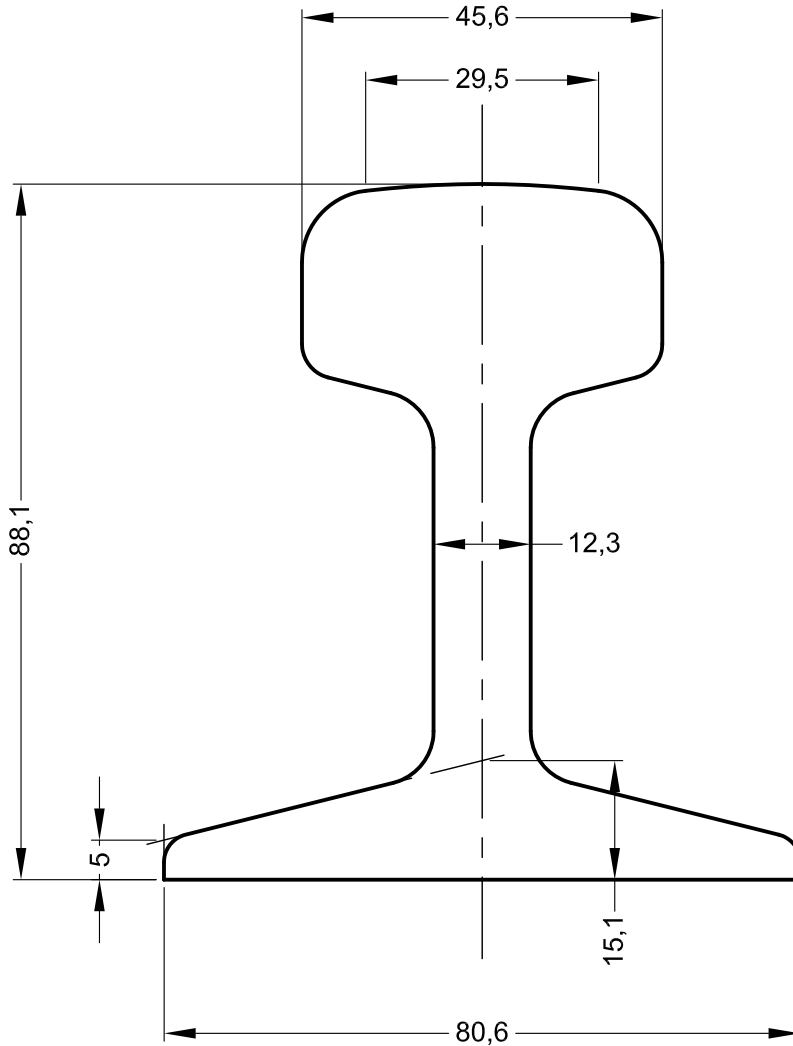

NOTE: THE PROPERTIES SPECIFIED BELOW HAVE BEEN CALCULATED USING AUTOCAD SOFTWARE AND ARE ACCURATE AT THE TIME OF THIS DRAWING ISSUE. THESE FIGURES MAY DIFFER SLIGHTLY FROM THOSE PUBLISHED IN THE STANDARD FOR THE RAIL.

**GANTRAIL**<sup>®</sup>

Rail Mounting Systems

THE TECHNICAL DATA CONTAINED IN THIS DRAWING IS THE PROPERTY OF GANTRY RAILING LIMITED AND IS SUBJECT TO COPYRIGHT ©

Gantry Railing Limited

SUDMEADOW ROAD, HEMPSTED  
GLOUCESTER GL2 5HG, ENGLAND  
Tel: (01452)300688 Fax (01452)300198  
International Dialling # 44.1452  
<http://www.gantrail.com>  
E-Mail: [info@gantrail.com](mailto:info@gantrail.com)

Rail Designation	BS C40		
Rail Origin	UK		
Standard	BS 248 1969		
Area of section	2534 mm <sup>2</sup>		
Calculated Mass	20 kg/m		
Neutral Axis to base	43.8 mm		
Moment of Inertia	I <sub>xx</sub>	246 cm <sup>4</sup>	I <sub>yy</sub> 51 cm <sup>4</sup>