

2520/24

Gantrail Bolted Fixing

www.gantrail.com

UK Patent Number GB2551404



The GANTRAIL 2520/24 adjustable crane rail clip is designed to fix heavy rails in the most arduous applications. It can withstand a horizontal force from the rail of 75kN (7.6 tonnes). Its low profile allows it to be used with cranes that are fitted with guide rollers.

SPECIFICATIONS:

BOLT GRADE	8.8	10.9
MAX SIDE LOAD (kN)	75	100
BOLT TORQUE (Nm)	390	600

24mm HORIZONTAL RAIL ADJUSTMENT

DIMENSIONS (mm):

REF No.	X	Y (FULL NUT)	Y (THIN NUT)	Z	WEIGHT kg
2520/24/45	45	50	45	32	1.1

* weight without nut and bolt.

2520/24/45 clip comprises 2524/20/45 clip body and 2520 Cam

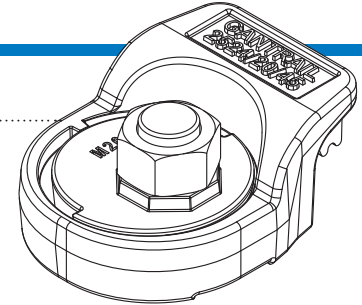

2520/24

FEATURES

- The clip has a unique self-tightening mechanism (patent pending)
- The unique design ensures that incorrect installation is avoided
- The clip is bolted to the rail support.
- The two main parts are locked together on tightening the nut.
- A special vulcanised rubber block applies a controlled force to the rail.

COMPONENTS

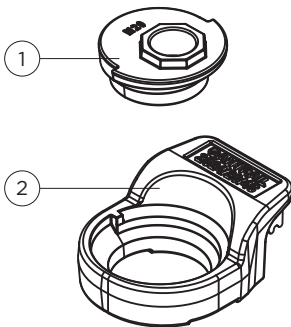

1. Clip cam
2. Clip body with integral rubber block

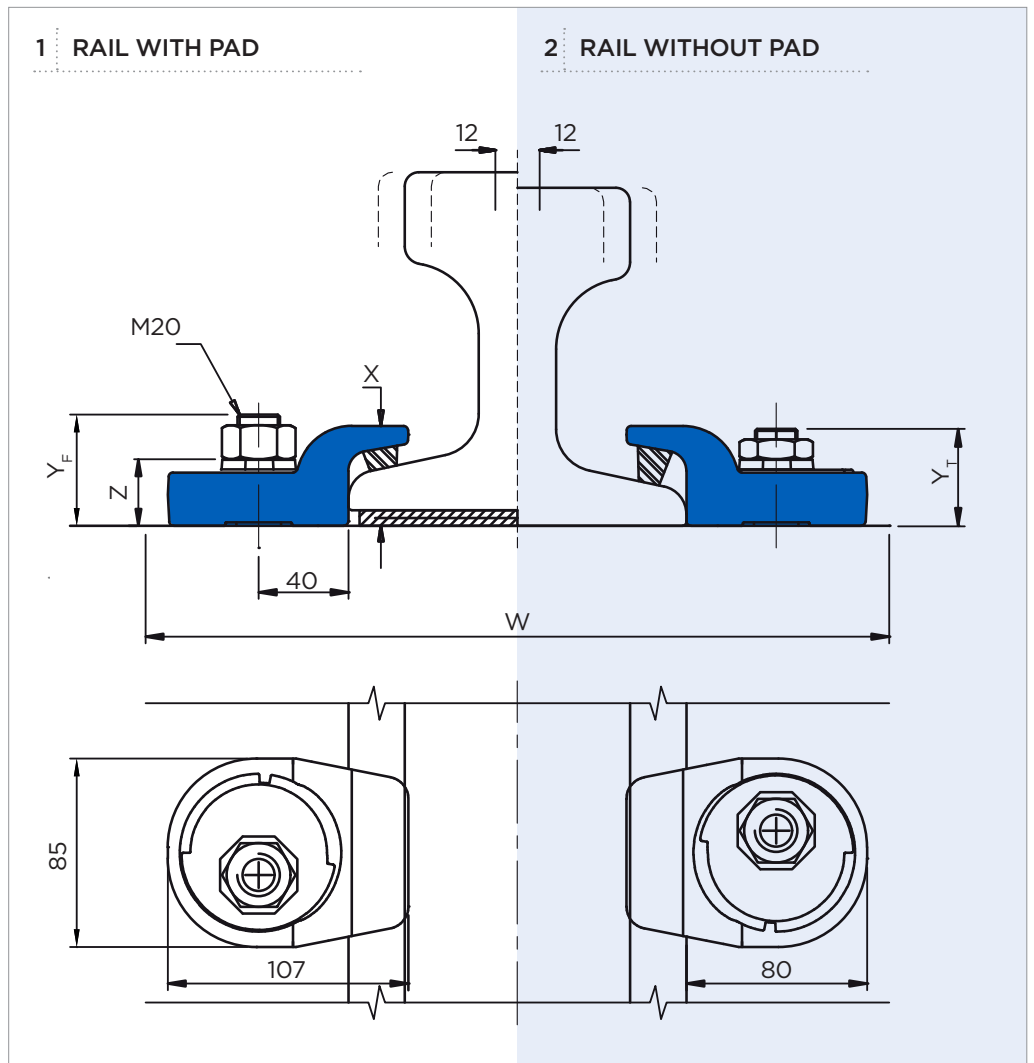

Minimum assembly width - $W = \text{Rail width (F)} + 184\text{mm}$

2520/24

Gantrail Bolted Fixing

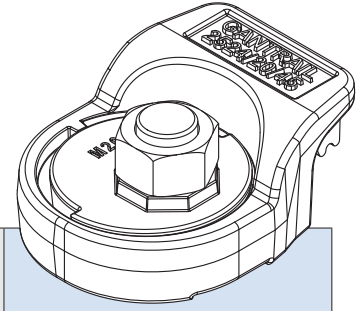

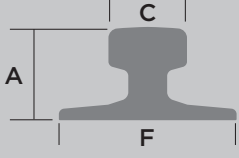
	F mm	C mm	A mm	1. CLIP REFERENCE FOR PAD MOUNTED RAIL	2. CLIP REFERENCE FOR RAIL WITHOUT PAD*
68 kg	152	75	186	2520/24/45	2520/24/45
73 kg	146	70	157	2520/24/45	2520/24/45
86 kg	165	102	102	2520/24/45	2520/24/45
A120	220	120	105	2520/24/45	2520/24/45
A150	220	150	150	2520/24/45	2520/24/45
MRS 73	146	70	157	2520/24/45	2520/24/45
MRS 86	165	102	102	2520/24/45	2520/24/45
MRS 87A	152	102	152	2520/24/45	2520/24/45
CR 73	140	100	135	2520/24/45	2520/24/45
CR 100	140	100	135	2520/24/45	2520/24/45
QU 120	150	100	150	2520/24/45	2520/24/45
ISCR 120	170	120	170	2520/24/45	2520/24/45
SP 120	170	120	170	2520/24/45	2520/24/45
171 CR	152	103	152	2520/24/45	2520/24/45
175 CR	152	102	152	2520/24/45	2520/24/45

This clip can be used for a wider selection of rails than illustrated.

Please contact GANTRAIL for the full range of possible rails. All rails can be fastened with bolted or welded base clips. GANTRAIL may change or improve their products and also alter specifications without notice.

INSTALLATION INSTRUCTIONS:

The hexagon headed fixing bolt can be inserted from above or below the supporting structure - see adjacent configurations.

TIGHTENING TORQUE
Grade 8.8 bolt 390Nm
Grade 10.9 bolt 600Nm

Please contact GANTRAIL, for full installation instructions.

BOLT CONFIGURATIONS

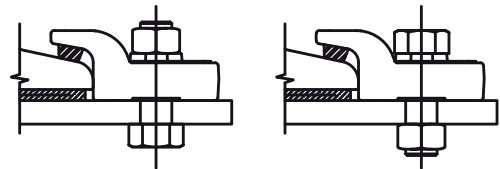

A world of crane rail expertise.

www.gantrail.com



Gantry Railing Ltd
Unit 11A
Barnett Way
Barnwood
Gloucester GL4 3QA
United Kingdom

Tel: +44 (0) 1452 300688
E-mail: info@gantrail.com



2520/24/DO/01/25