

8219/20

Gantrail Welded Base Fixing

www.gantrail.com



Gantrail®

A world of crane rail expertise

8219/20

The **GANTRAIL 8219/20** adjustable crane rail clip is designed to fix the largest rails in the most arduous applications. It can withstand a horizontal force from the rail of 200kN (20.4 tonnes). Its low profile allows it to be used with cranes that are fitted with guide rollers.

SPECIFICATIONS:

MAX SIDE LOAD 200kN
20mm HORIZONTAL RAIL ADJUSTMENT

DIMENSIONS (mm):

REF No.	X	Y (FULL NUT)	Y (THIN NUT)	Z	WEIGHT* kg
8219/20/40	40	60	55	37	2.73

* weight without nut, bolt and washer.

NOTE: Clip assembly not supplied with nut, bolt and washer unless requested

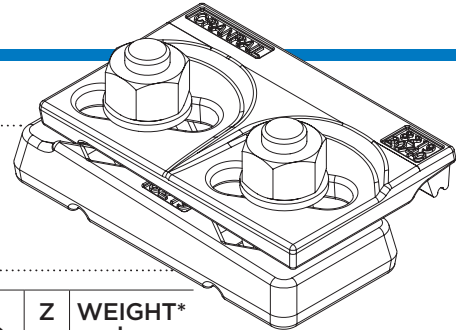

FEATURES

- The proven design has been used successfully for many years throughout the world.
- The clip is welded to the rail support. No access is required from below.
- The two main parts are locked together on tightening the grade 8.8 bolts.
- The clip has a self-tightening mechanism.
- A special vulcanised rubber block applies a controlled force to the rail.

COMPONENTS

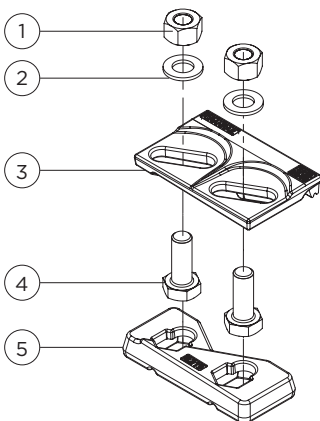

1. Nuts
2. Hardened washers
3. Clip cap with integral rubber block
4. M20 hexagon headed bolts
5. Weldable base

1 RAIL WITH PAD

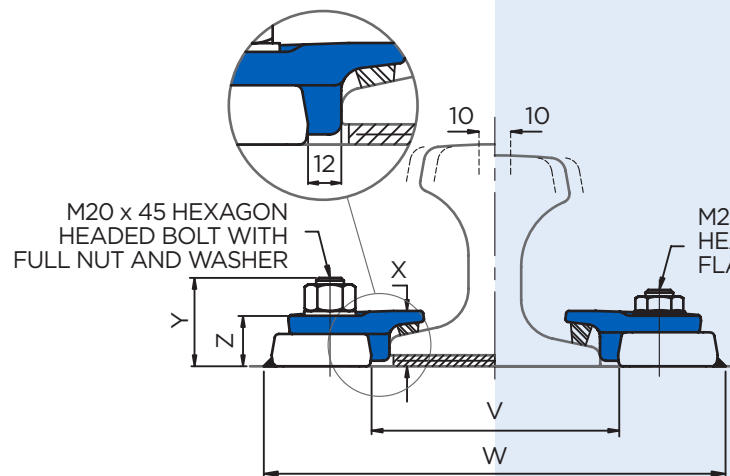

2 RAIL WITHOUT PAD

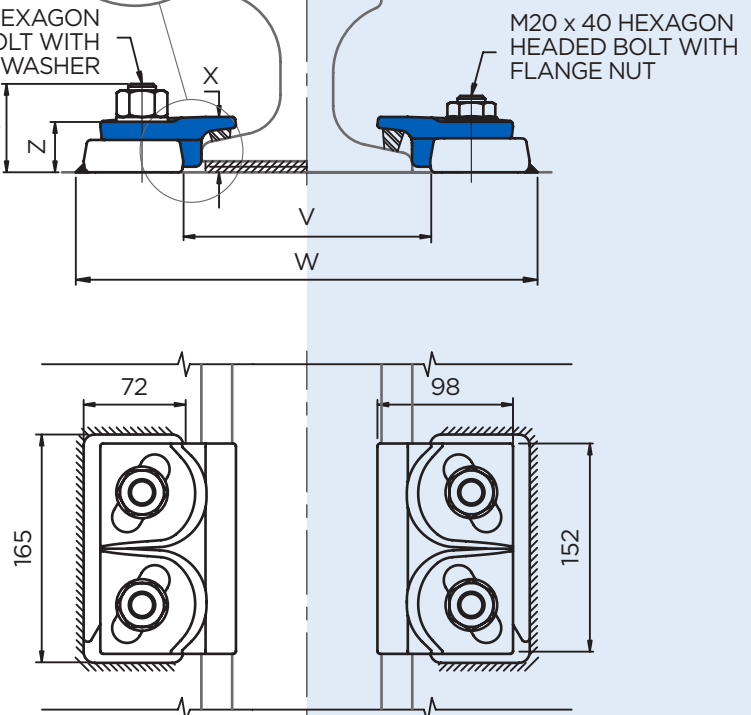

Minimum assembly width - W = Rail width (F) + 187mm V = Rail width (F) + 24mm

8219/20

Gantrail Welded Base Fixing

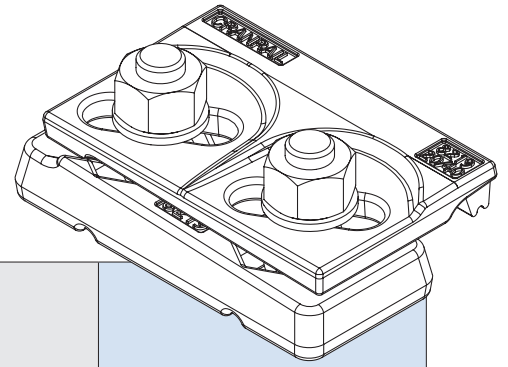

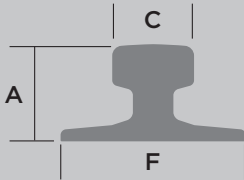
	F mm	C mm	A mm	1. CLIP REFERENCE FOR RAIL WITH PAD	2. CLIP REFERENCE FOR RAIL WITHOUT PAD*
A 100	200	100	95	8219/20/40	8219/20/40
A 120	220	120	105	8219/20/40	8219/20/40
A 150	220	150	150	8219/20/40	8219/20/40
89 kg CR	178	102	114	8219/20/40	8219/20/40
MRS 86	165	102	102	8219/20/40	8219/20/40
MRS 87 A (PRI85R)	152	102	152	-	8219/20/40
MRS 125	180	120	180	-	8219/20/40
MRS 221	220	220	160	-	8219/20/40
ISCR 100	150	102	150	8219/20/40	8219/20/40
ISCR 120	170	120	170	8219/20/40	8219/20/40
ISCR 140	170	140	170	-	8219/20/40
QU 100	150	100	150	8219/20/40	8219/20/40
QU 120	170	120	170	8219/20/40	8219/20/40
171 CR (MRS 85)	150	103	152	8219/20/40	8219/20/40
175 CR (MRS 87B)	152	102	152	8219/20/40	8219/20/40
ISCOR 57	140	70	165	8219/20/40	8219/20/40
CR 73	140	100	135	8219/20/40	8219/20/40
CR 100	155	120	150	-	8219/20/40
73 kg AS	146	70	157	-	8219/20/40
86 kg AS	165	102	102	8219/20/40	8219/20/40

This clip can be used for a wider selection of rails than illustrated.

Please contact GANTRAIL for the full range of possible rails. All rails can be fastened with bolted or welded base clips. GANTRAIL may change or improve their products and also alter specifications without notice.

INSTALLATION INSTRUCTIONS:

Weld along back and sides of clip base with a 5mm throat thickness fillet weld. Weld in 'V' with a 3mm throat thickness fillet weld. Use low hydrogen electrodes. Recommended electrodes AWS E7018 or E7028. Clip base is made from weldable grade steel.

If a continuous weld around the base is required, this is possible. Please consult GANTRAIL for guidance.

TIGHTENING TORQUE 250Nm

Please contact GANTRAIL, for full installation instructions.

WELD DETAIL

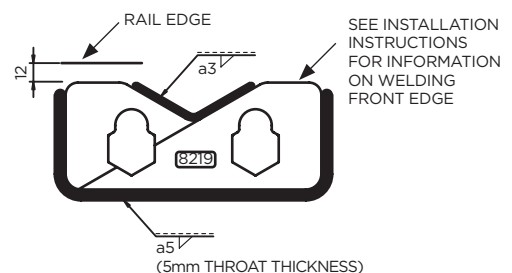

A world of crane rail expertise.

www.gantrail.com



Gantry Railing Ltd
Unit 11A
Barnett Way
Barnwood
Gloucester GL4 3QA
United Kingdom

Tel: +44 (0) 1452 300688
E-mail: info@gantrail.com



8219/20/DO/01/25