

9116/10

Gantrail Welded Base Fixing

www.gantrail.com



The GANTRAIL 9116/10 adjustable crane rail clip is designed to fix light rails in the most arduous applications. It can withstand a horizontal force from the rail of 40kN (4.1 tonnes). Its low profile allows it to be used with cranes that are fitted with guide rollers.

SPECIFICATIONS:

MAX SIDE LOAD 40kN
10mm HORIZONTAL RAIL ADJUSTMENT

DIMENSIONS (mm):

REF No.	X	Y	Z	WEIGHT kg
9116/10/25	25	41	24	0.67
9116/10/32	32	41	24	0.69

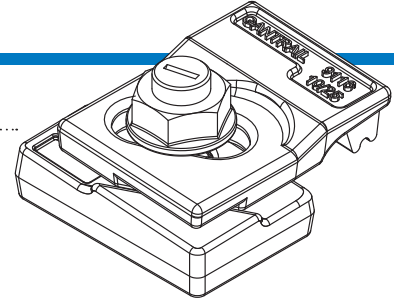

9116/10

FEATURES

- The proven design has been used successfully for many years throughout the world.
- The clip is welded to the rail support. No access is required from below.
- The two main parts are locked together on tightening the grade 8.8 bolt.
- The clip has a self-tightening mechanism.
- A special vulcanised rubber block applies a controlled force to the rail.

COMPONENTS

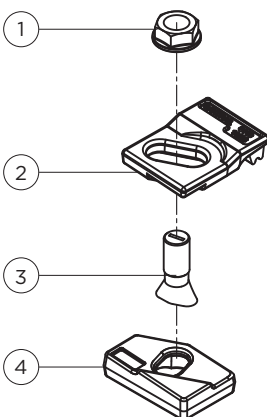

1. Flange nut
2. Clip cap with integral rubber block
3. M16 Captive bolt
4. Weldable base

1 RAIL WITH PAD

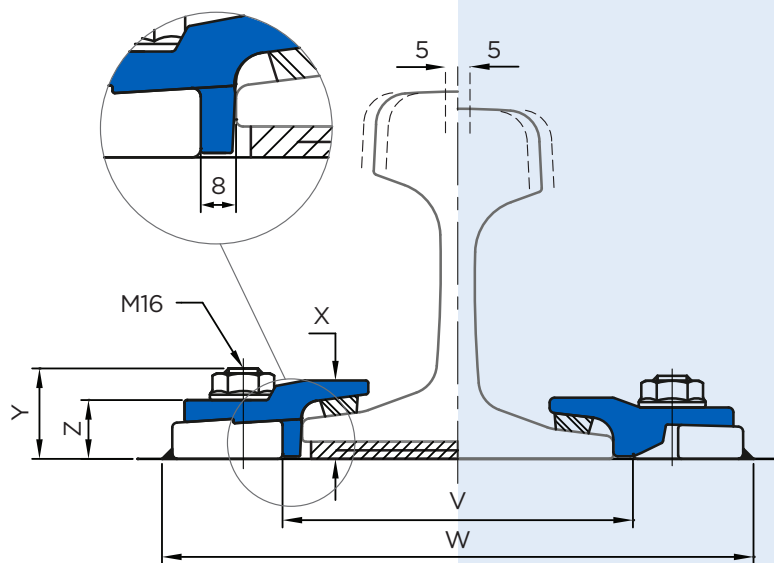

2 RAIL WITHOUT PAD

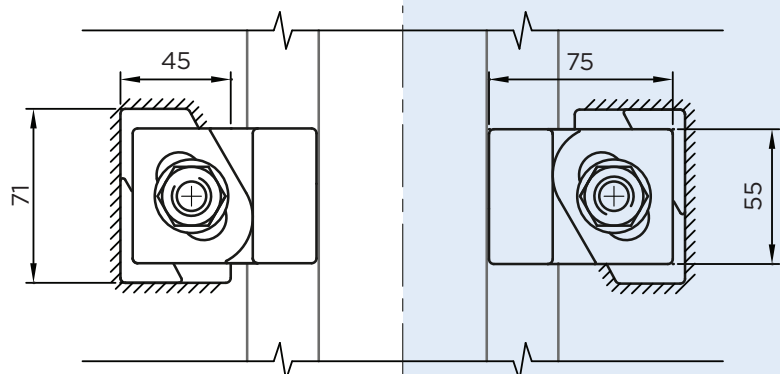

Minimum assembly width - $W = \text{Rail width (F)} + 118\text{mm}$ $V = \text{Rail width (F)} + 16\text{mm}$

9116/10

Gantrail Welded Base Fixing

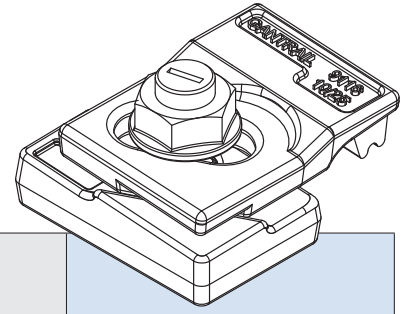

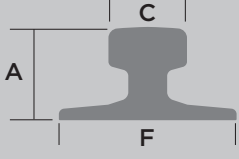
	F mm	C mm	A mm	1. CLIP REFERENCE FOR RAIL WITH PAD	2. CLIP REFERENCE FOR RAIL WITHOUT PAD
A 45	125	45	55	9116/10/32	9116/10/25
A 55	150	55	65	9116/10/32	9116/10/25
A 65	175	65	75	9116/10/32	9116/10/25
A 75	200	75	85	9116/10/32	9116/10/25
S 20	82	44	100	9116/10/32	9116/10/25
S 30	108	60	108	9116/10/32	9116/10/25
S 33	105	58	134	9116/10/32	9116/10/25
S 41	125	67	138	9116/10/32	9116/10/25
ISCR 80	130	82	130	9116/10/32	9116/10/25
QU 70	120	70	120	9116/10/32	9116/10/25
QU 80	130	80	130	9116/10/32	9116/10/25
ISCOR 30	110	57	110	9116/10/32	9116/10/25
ISCOR 40	127	64	127	9116/10/32	9116/10/25
JIS 37	122	63	122	9116/10/32	9116/10/25
JIS 40N	122	64	140	9116/10/32	9116/10/25
22 kg BHP	94	51	94	9116/10/32	9116/10/25
31 kg AS	108	64	118	9116/10/32	9116/10/25
41 kg AS	127	64	137	9116/10/32	9116/10/25
UIC 54	140	70	159	9116/10/32	9116/10/25

This clip can be used for a wider selection of rails than illustrated.

Please contact GANTRAIL for the full range of possible rails. All rails can be fastened with bolted or welded base clips. GANTRAIL may change or improve their products and also alter specifications without notice.

INSTALLATION INSTRUCTIONS:

Weld all round the clip base, except the side closest and parallel to the rail, with a 3mm throat thickness fillet weld, using low hydrogen electrodes. Recommended electrodes AWS E7018 or E7028. Clip base is made from weldable grade steel.

If a continuous weld around the base is required, this is possible. Please consult GANTRAIL for guidance.

TIGHTENING TORQUE 125Nm

Please contact GANTRAIL, for full installation instructions.

WELD DETAIL

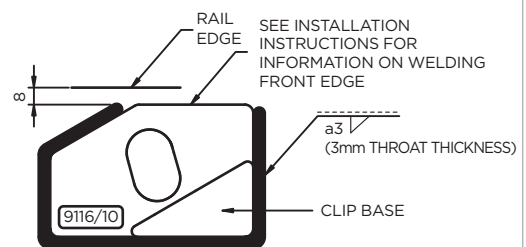

A world of crane rail expertise.

www.gantrail.com



Gantry Railing Ltd
Unit 11A
Barnett Way
Barnwood
Gloucester GL4 3QA
United Kingdom

Tel: +44 (0) 1452 300688
E-mail: info@gantrail.com



9116/10/DO/01/25