

Mark 7

Gantrail Steel Reinforced Resilient Pad For Continuous Rail Support

www.gantrail.com



The use of Gantrail Mark 7 Crane Rail Pad between a rail and its support substantially improves the performance of heavy duty crane tracks. Cranes apply very high forces to the structures on which they are mounted. The pad significantly reduces the stress between the rail and its support. The Gantrail pad is one of the three key ingredients in achieving a reliable track.

These are:-

- Resilient Pad
- Strong, adjustable clips
- Continuously welded rail

SPECIFICATIONS:

The pad width should be nominally 5mm less than the rail foot width.

DIMENSIONS:

PART No	W mm (Flat)
MK7-098	98
MK7-118	118
MK7-128	128
MK7-134	134
MK7-147	147
MK7-157	157
MK7-168	168
MK7-195	195
MK7-215	215

*Pad width may vary by ± 5 mm

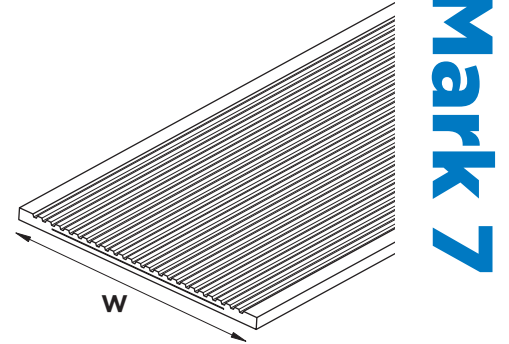

Gantrail flat pad is normally supplied in 12 metre lengths of the widths shown but is also available in lengths and widths to suit customer specification. This may result in longer lead times - Please contact Gantrail for guidance.

FEATURES

- The Gantrail pad has been designed with a fluted top surface. This results in a two stage stiffness characteristic. On loading, the voids in the top allow the Gantrail clips to pre-compress the pad a small amount. On increasing the wheel loading, the voids are filled and the pad becomes stiffer. This ensures that the rail is not over stressed.
- The pad is reinforced with a steel strip to ensure high lateral stiffness and prevent movement from below the rail.

CONTINUOUS SUPPORT

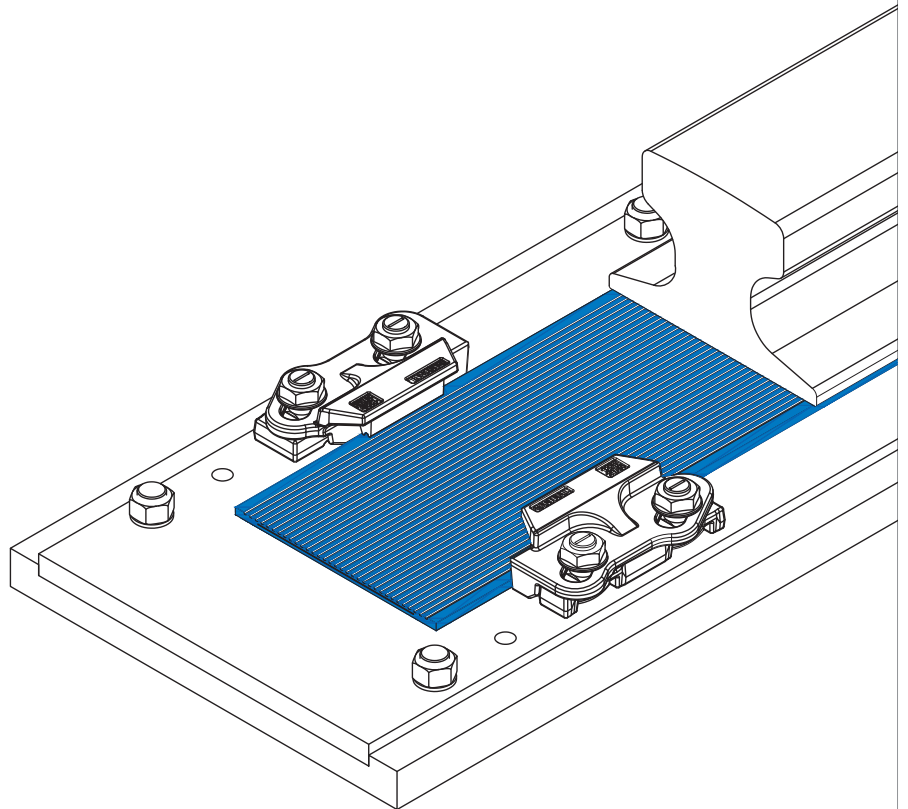

COMPONENTS

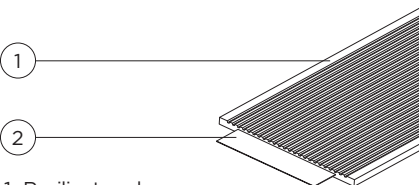

1. Resilient pad
2. Steel reinforcement

Gantrail can supply standard design details and technical information in support of all crane rail applications.

Mark 7

Gantrail Steel Reinforced Resilient Pad For Continuous Rail Support

Gantrail Mark 7 pads are manufactured from wear resistant durable vulcanised rubber. They are unaffected by oil, grease or ultraviolet light. They have been tested to many times the design loads and show complete recovery. The pad incorporates a bonded steel reinforcement strip which is encapsulated for protection against corrosion.

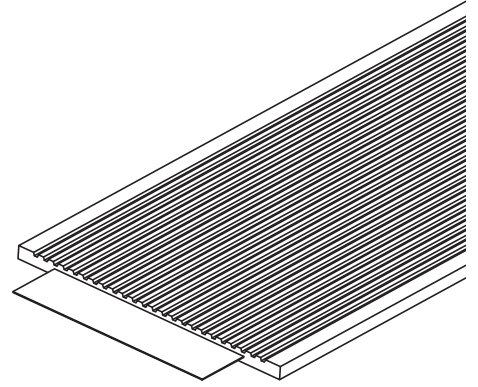

TYPICAL PROPERTIES

Material	Rubber	
Shore hardness (ISO 48:1994)	75 ± Shore A	
Tensile strength (ISO 37:1994)	12.5 N/mm ²	Minimum
Elongation (ISO 37:1994)	250%	Minimum
Temperature range	-25°C to 100°C	
Oil resistance ASTM Oil No.2	Swelling 5%	Maximum

Note: Typical properties shown, but actual properties may vary according to batch. Gantrail will supply pad suitable for the intended loads and application.

PAD FOR CONTINUOUSLY SUPPORTED APPLICATIONS

Gantrail 'flat' pad is suitable for all applications where soft mounting is desirable. Historically, pad was provided 1.5mm thicker at the centre than the edges due to the concave shape of the base of some rails. It has been shown that there is no significant benefit in using this 'crowned' pad but Gantrail offer it to meet some older specifications.

STIFFNESS CHARACTERISTICS

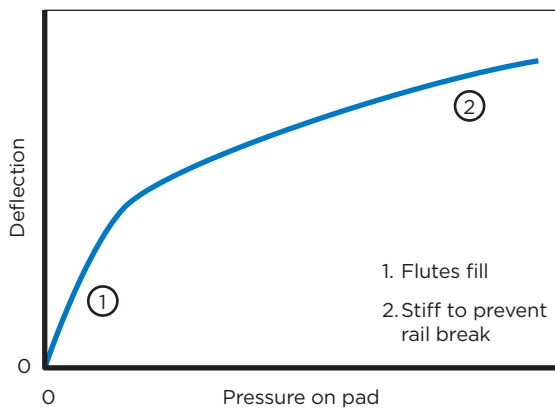

MARK 7 PROFILE

MK7 Flat pad

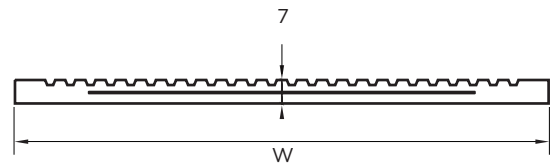

INSTALLATION INSTRUCTIONS:

Rail pad should be narrower than the rail it is supporting (nominally 5mm). The pad is normally supplied in 12 metre lengths. The flutes of the pad are placed facing upwards. The pad may be cut to precise length of rail. It can be cut with a hacksaw or jigsaw. No installed length of pad should be less than the spacing between three pairs of crane rail fixing clips. Before installing Mark 7 pad, the supporting area should be clean and free of oil, grease or any projections likely to damage the pad. It is preferable that the steel structure below the pad is not painted. If the rail is to be welded the pad should be protected from excessive heat during welding by being removed under the weld or by being protected with a thermal barrier. Our technical department will be pleased to advise on the suitability of Mark 7 pad in specific installation conditions.

Gantrail reserves the right to make, from time to time, such departures from the detail specifications as may be required to permit improvements in the design of its products and to allow the use of batches of material that fulfil the loading requirements of the intended application. The information included herein is believed to be accurate and reliable. However, Gantrail assumes no responsibility for its use; nor for any infringements of patents or other rights of third parties which may result from its use.

A world of crane rail expertise.

www.gantrail.com



Gantry Railing Ltd
Unit 11A
Barnett Way
Barnwood
Gloucester GL4 3QA
United Kingdom

Tel: +44 (0) 1452 300688
E-mail: info@gantrail.com



Mark 7 Resilient Pad/DO/01/25