

2219/20

Gantrail Welded Base Fixing

www.gantrail.com



GANTRAIL
A world of crane rail expertise

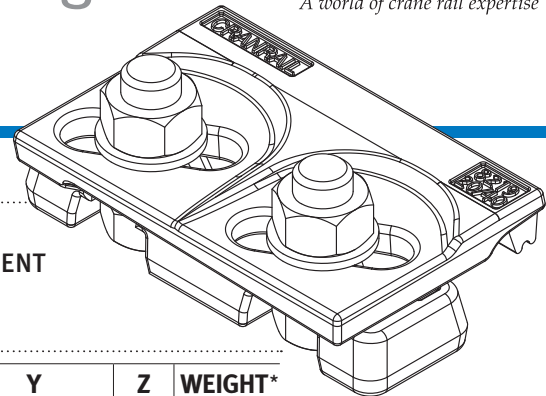

2219/20

The GANTRAIL 2219/20 adjustable crane rail clip is designed to fix the largest rails in the most arduous applications. It can withstand a horizontal force from the rail of 235kN (24 tonnes). Its low profile allows it to be used with cranes that are fitted with guide rollers.

SPECIFICATIONS:

MAX SIDE LOAD 235kN
20mm HORIZONTAL RAIL ADJUSTMENT

DIMENSIONS (mm):

| REF NO. | X | Y (FULL NUT) | Y (FLANGE NUT) | Z | WEIGHT* kg |
|------------|----|--------------|----------------|----|------------|
| 2219/20/40 | 40 | 60 | 55 | 37 | 2.23 |

* weight without nut, bolt and washer.

2219/20 clip comprises of 2119/20 base and 2219/20 base and 2219/20/40 cap

FEATURES

- The proven design has been used successfully for many years throughout the world.
- The clip is welded to the rail support. No access is required from below.
- The two main parts are locked together on tightening the grade 8.8 bolts.
- The clip has a self-tightening mechanism.
- A special vulcanised rubber block applies a controlled force to the rail.

COMPONENTS

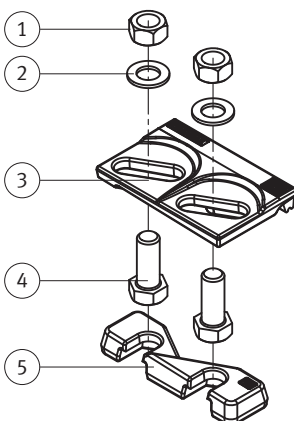

1. Nuts
2. Hardened washers
3. Clip cap with integral rubber block
4. M20 hexagon headed bolts
5. Weldable base

1 RAIL WITH PAD

2 RAIL WITHOUT PAD

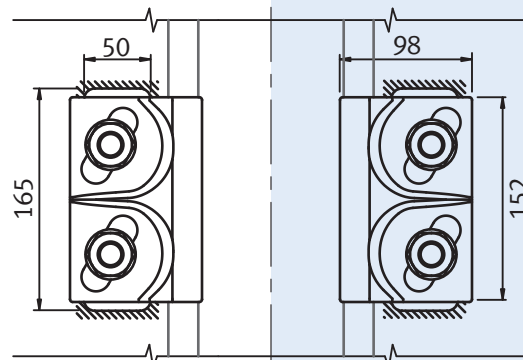
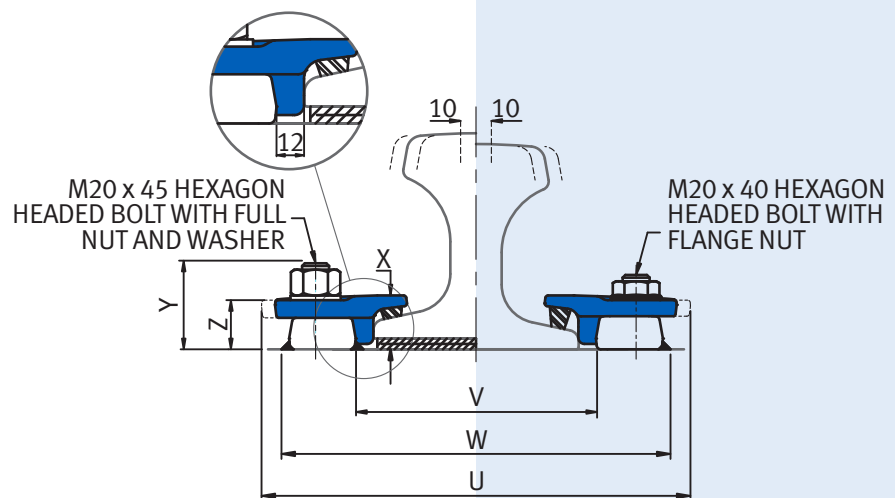

Minimum assembly width - W = Rail width (F) + 140mm **V = Rail width (F) + 24mm**
U = Rail width (F) + 131mm

2219/20

Gantrail Welded Base Fixing

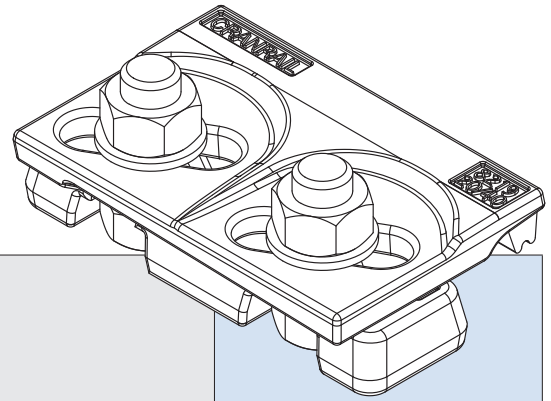

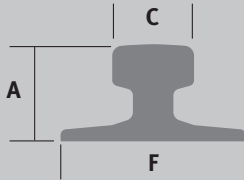
|  | F mm | C mm | A mm | 1. CLIP REFERENCE FOR RAIL WITH PAD | 2. CLIP REFERENCE FOR RAIL WITHOUT PAD |
|---|---------|---------|---------|--|---|
| A 100 | 200 | 100 | 95 | 2219/20/40 | 2219/20/40 |
| A 120 | 220 | 120 | 105 | 2219/20/40 | 2219/20/40 |
| A 150 | 220 | 150 | 150 | 2219/20/40 | 2219/20/40 |
| 89 kg CR | 178 | 102 | 114 | 2219/20/40 | 2219/20/40 |
| MRS 86 | 165 | 102 | 102 | 2219/20/40 | 2219/20/40 |
| MRS 87 A (PRI85R) | 152 | 102 | 152 | - | 2219/20/40 |
| MRS 125 | 180 | 120 | 180 | - | 2219/20/40 |
| MRS 221 | 220 | 220 | 160 | - | 2219/20/40 |
| ISCR 100 | 150 | 102 | 150 | 2219/20/40 | 2219/20/40 |
| ISCR 120 | 170 | 120 | 170 | 2219/20/40 | 2219/20/40 |
| ISCR 140 | 170 | 140 | 170 | - | 2219/20/40 |
| QU 100 | 150 | 100 | 150 | 2219/20/40 | 2219/20/40 |
| QU 120 | 170 | 120 | 170 | 2219/20/40 | 2219/20/40 |
| 171 CR (MRS 85) | 152 | 103 | 152 | 2219/20/40 | 2219/20/40 |
| 175 CR (MRS 87B) | 152 | 102 | 152 | 2219/20/40 | 2219/20/40 |
| ISCOR 57 | 140 | 70 | 165 | 2219/20/40 | 2219/20/40 |
| CR 73 | 140 | 100 | 135 | 2219/20/40 | 2219/20/40 |
| CR 100 | 155 | 120 | 150 | - | 2219/20/40 |
| 73 kg AS | 146 | 70 | 157 | - | 2219/20/40 |
| 86 kg AS | 165 | 102 | 102 | 2219/20/40 | 2219/20/40 |

THIS CLIP CAN BE USED FOR A WIDER SELECTION OF RAILS THAN ILLUSTRATED.

Please contact GANTRAIL for the full range of possible rails. All rails can be fastened with bolted or welded base clips. GANTRAIL may change or improve their products and also alter specifications without notice.

INSTALLATION INSTRUCTIONS:

Welds along back and sides of the base to be 6mm. The weld in the 'V' and front edges next to and parallel with rail to be 4mm throat thickness fillet weld. Use low hydrogen electrodes. Recommended electrodes AWS E7018 or E7028. Clip base is made from weldable grade steel.

* For rail without pad, weld closest to and parallel with the rail must be omitted. Please consult GANTRAIL for guidance.

TIGHTENING TORQUE 350Nm

Please contact GANTRAIL, for full installation instructions.

WELD DETAIL

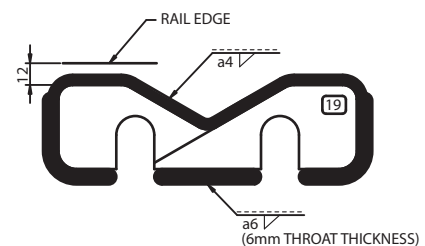

A world of crane rail expertise.

www.gantrail.com



Gantry Railing Ltd
Sudmeadow Road
Hempsted
Gloucester GL2 5HG
ENGLAND

Tel: +44 (0) 1452 300688
Fax: +44 (0) 1452 300198
E-mail: info@gantrail.com

Gantrail (Middle East) Ltd
P O Box 61428
Jebel Ali Free Zone
Dubai
United Arab Emirates

Tel: +971 4 8812 935
Fax: +971 4 8812 936
E-mail: gme@gantrail.com



Certificate No. 5180

2219/20/ET/09/14