

4116/10

Gantrail Bolted Fixing

www.gantrail.com



GANTRAIL
A world of crane rail expertise

UK patent application No GB 1912155-7

The GANTRAIL 4116/10 adjustable crane rail clip is designed to fix light rails in the most arduous applications. It can withstand a horizontal force from the rail of up to 50kN (5.0 tonnes). Its low profile allows it to be used with cranes that are fitted with guide rollers.

SPECIFICATIONS:

BOLT GRADE	8.8	10.9
MAX SIDE LOAD (kN)	38	50
BOLT TORQUE (Nm)	200	300

10mm HORIZONTAL RAIL ADJUSTMENT

DIMENSIONS (mm):

REF NO.	X	Y (FULL NUT)	Y (THIN NUT)	Z	WEIGHT kg
4116/10/28	28	35	30	20	0.26
4116/10/35	35	35	30	20	0.27

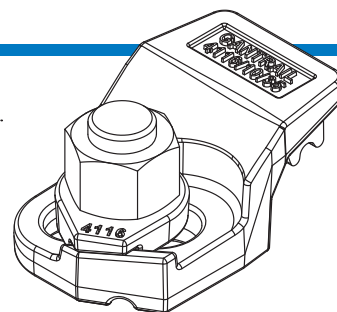

4116/10

FEATURES

NEW

- Unique 'self-engaging' feature (patent pending) ensures all load bearing parts are in contact upon tightening of the bolt
- Offset washer design to ensure intuitive fool-proof installation
- Large clearance around nut to allow the use of impactor sockets
- Drain hole to prevent build up of contaminants and standing water

RETAINED

- The proven 'double-wedge' design causes self-locking and self-tightening
- The two parts are locked together upon tightening of the nut
- The clip is bolted to the rail support from above or below
- A special vulcanised rubber block applies a controlled force to the rail

COMPONENTS

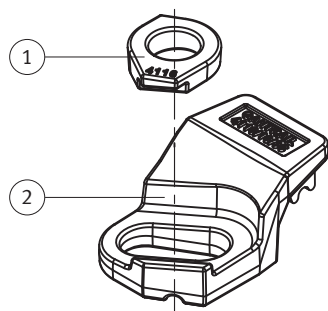

1. Special washer
2. Clip with integral rubber block

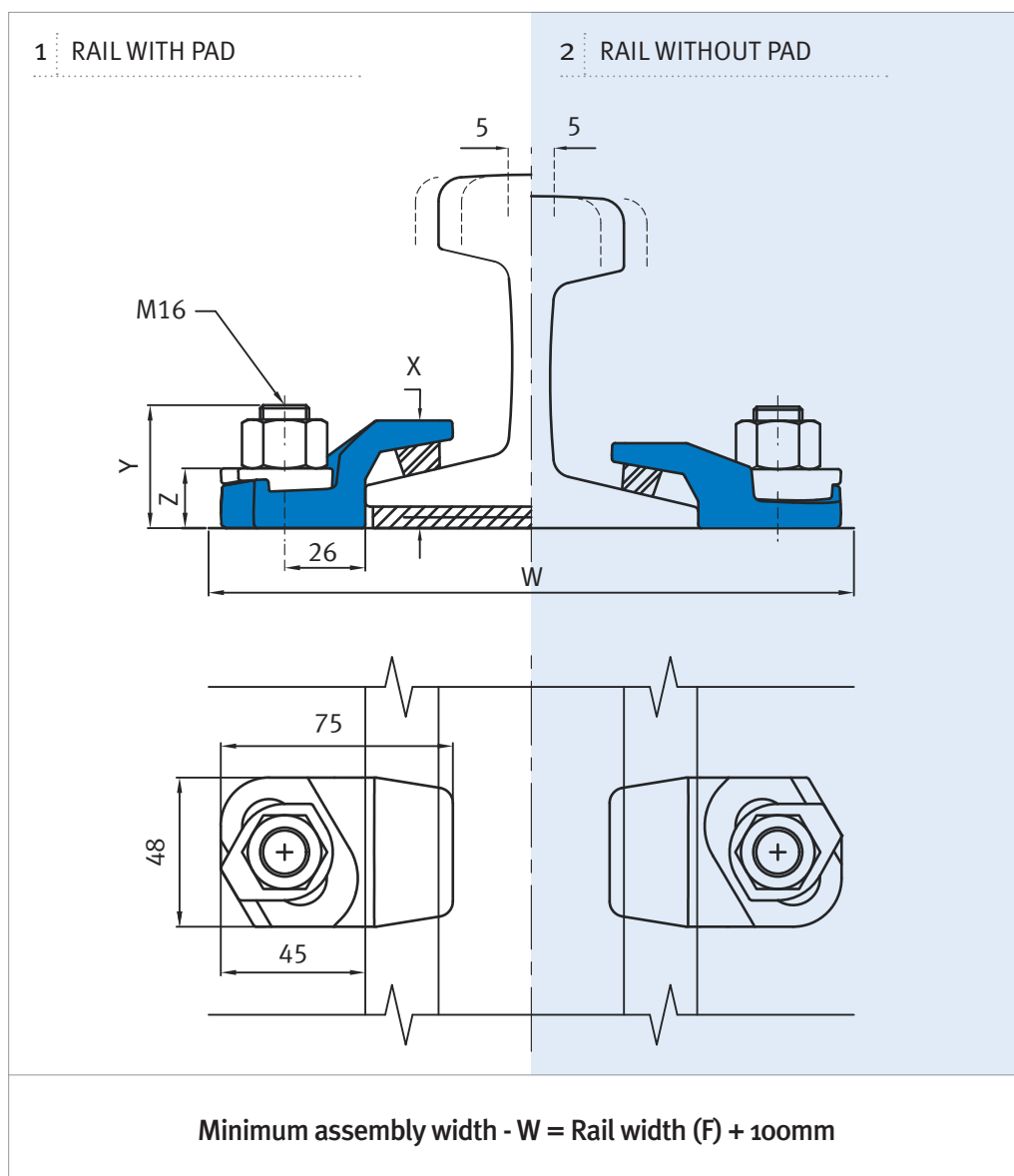

4116/10

Gantrail Bolted Fixing

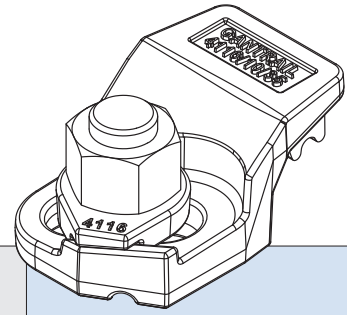

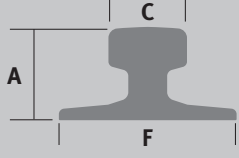
	F mm	C mm	A mm	1. CLIP REFERENCE FOR RAIL WITH PAD	2. CLIP REFERENCE FOR RAIL WITHOUT PAD
A 45	125	45	55	4116/10/35	4116/10/28
A 55	150	55	65	4116/10/35	4116/10/28
A 65	175	65	75	4116/10/35	4116/10/28
S 14	70	38	80	4116/10/35	4116/10/28
S 20	82	44	100	4116/10/35	4116/10/28
S 30	108	60	108	4116/10/35	4116/10/28
S33	105	58	134	4116/10/35	4116/10/28
S 41	125	67	138	4116/10/35	4116/10/28
BS 50 '0'	100	52	100	4116/10/35	4116/10/28
AFNOR 26	100	50	110	4116/10/35	4116/10/28
AFNOR 30	106	56	126	4116/10/35	4116/10/28
ASCE 60	108	60	108	4116/10/35	4116/10/28
ASCE 80	127	64	127	4116/10/35	4116/10/28
ASCE 85	132	65	132	4116/10/35	4116/10/28
ISCOR 22	95	50	95	4116/10/35	4116/10/28
ISCOR 30	110	57	110	4116/10/35	4116/10/28
JIS 22	93.7	50.8	93.7	4116/10/35	4116/10/28
JIS 37	122	63	122	4116/10/35	4116/10/28
JIS 40	122	64	140	4116/10/35	4116/10/28
15 kg.m BHP	79	43	79	4116/10/35	4116/10/28
22 kg.m BHP	94	51	94	4116/10/35	4116/10/28

THIS CLIP CAN BE USED FOR A WIDER SELECTION OF RAILS THAN ILLUSTRATED. Please contact GANTRAIL for the full range of possible rails. All rails can be fastened with bolted or welded base clips. GANTRAIL may change or improve their products and also alter specifications without notice.

INSTALLATION INSTRUCTIONS:

The hexagon headed fixing bolt can be inserted from above or below the supporting structure – see adjacent configurations.

If it is desired to fix the clip with a welded stud, this may be possible. Please consult GANTRAIL for guidance.

TIGHTENING TORQUE

Grade 8.8 bolt 200Nm
Grade 10.9 bolt 300Nm

Please contact GANTRAIL for full installation instructions.

BOLT CONFIGURATIONS

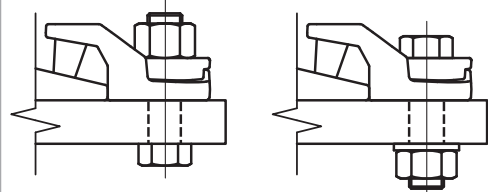

Gantrail reserve the right to improve their products and also alter specifications without notice.

Gantrail disclaim any and all liability for any errors, inaccuracies or incompleteness contained in this datasheet.

POSITIONING OF SPECIAL WASHER

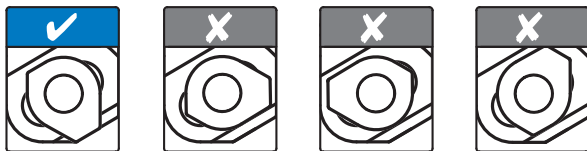

A world of crane rail expertise.

www.gantrail.com



Gantry Railing Ltd
Sudmeadow Road
Hempstead
Gloucester GL2 5HG
ENGLAND

Tel: +44 (0) 1452 300688
Fax: +44 (0) 1452 300198
E-mail: info@gantrail.com



Certificate No. 5180

4116/10/MT/04/20